

# Visual System Simulator™



Advancing the wireless revolution™



# Advancing the Design of Communications Systems

“ VSS has increased my productivity by providing more accurate results...and has helped us optimize our system engineering design flow. ”  
*Sy Prestwich, Co-founder, S5 Wireless*

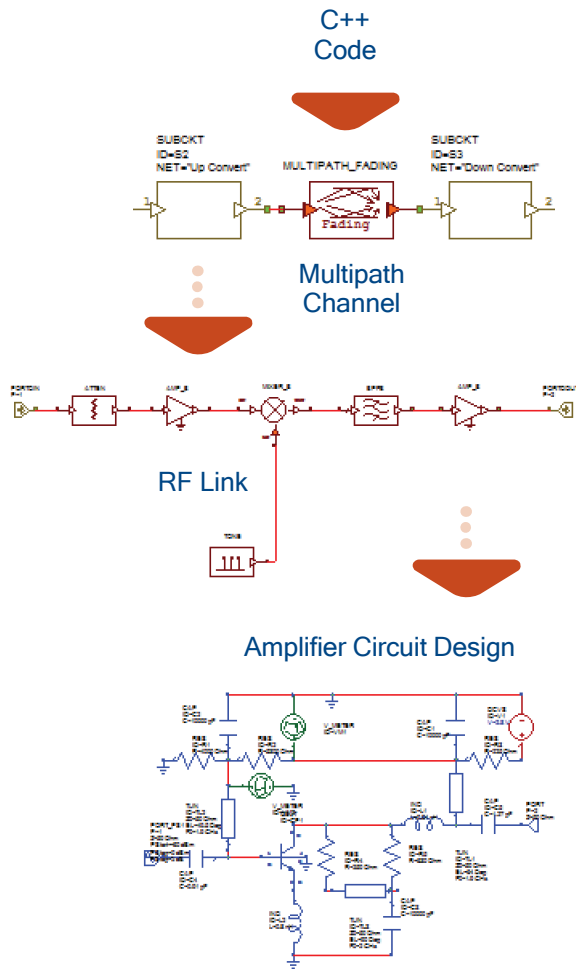

VSS software allows you to use, for example, custom C++ code models and circuit level component in your system design.

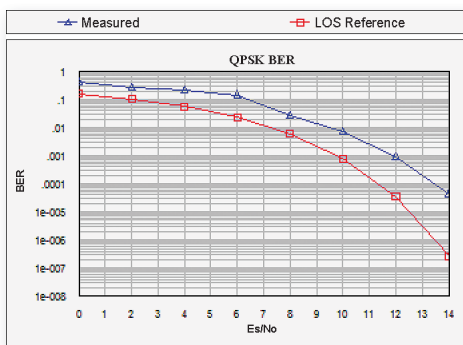

The VSS design environment helps you reduce time-to-market by eliminating unnecessary “learning-curve” overhead.

Visual System Simulator™ (VSS) software is a comprehensive environment for the end-to-end design and optimization of communications systems. The VSS design software enables you to craft the best architecture for a communications system and optimize each of its components. It reduces cost by eliminating rework and ensuring that components are not over-specified and unnecessarily expensive. With VSS software you can begin at the behavioral level, progress to the component level co-simulating with Microwave Office® or Analog Office® design suites, and even use actual device measurements to validate the final design.

## PRODUCTIVITY-FOCUSED DESIGN FLOW

AWR's founding principle is to provide a superior design flow for RF and microwave professionals – inclusive of system level simulation – so that it increases user-productivity and shortens design cycle time.

**Unified Data Model™: schematic and layout** The cornerstone of AWR's design flow is its Unified Data Model architecture. And like all of AWR's design tools, VSS exploits this single, object-oriented database, which is synchronized for schematic and layout from its core—and not through many layers of software. So whether you're driving the design from the schematic, simulation, or layout, VSS gives you everything you need to bring your design ideas from concept to simulation and ultimately physical implementation—all in a single platform.

## USER-FLEXIBLE DESIGN ENVIRONMENT

VSS software benefits from AWR's long standing commitment to readily enable third-party point tools to function within its design flow framework in order to provide you with a user-flexible design environment that provides you with a complete solution regardless of the stage of the design process.

**C++ and Matlab®: standard tools for system designers** VSS's user-flexible design environment enables the creation of custom models through C++ code. Additionally, with Matlab co-simulation, you can readily import legacy or custom Matlab code into VSS for enhanced system simulation capability.

**R&S®WinIQSIM2™: Rhode & Schwarz communications standards** Fully integrated, WinIQSIM2™ software generates complex digitally modulated and standard conform signals that can be used in VSS system diagrams as signal sources for simulation.

**TestWave™: hardware in the loop simulations** VSS's TestWave software module links test and measurement with system simulation by integrating instruments such as network and spectrum analyzers into VSS via LAN or GPIB.

## INNOVATIVE TECHNOLOGIES

All of AWR's software tools are continually enhanced to ensure they represent the state-of-the-art in both technology and user-productivity. AWR innovations specific to VSS include:

**RF Architectural Tool (RFA™)** delivers two technologies that enable you to streamline your product development process.

**RF Budget Analysis (RFB™)** enables you to make traditional RF cascaded measurements such as gain, noise figure, and third-order intercept, inclusive of image noise, and perform impedance mismatch along a communication link.

**RF Inspector (RFI™)** helps identify the cause of any intermodulation product of an RF link. It includes the effects of conversions, harmonics, and intermodulation.

Additional innovative features within the VSS software further enhance the user experience:

**Auto-configurable I/Q demodulator** - automatically configures itself to settings of the transmitted signal so you can understand the effect of component impairments on the modulated signals with minimum effort.

**Auto data-alignment for BER simulations** - uses VSS signal generators and the I/Q demodulator to automatically align transmitted-to-received data before performing a BER simulation so that you can perform component tradeoff studies with ease.

**Backward and forward propagation of time step** - makes system design one step easier by “backward propagation” and “forward propagation” of time step, so models automatically adjust their rates.

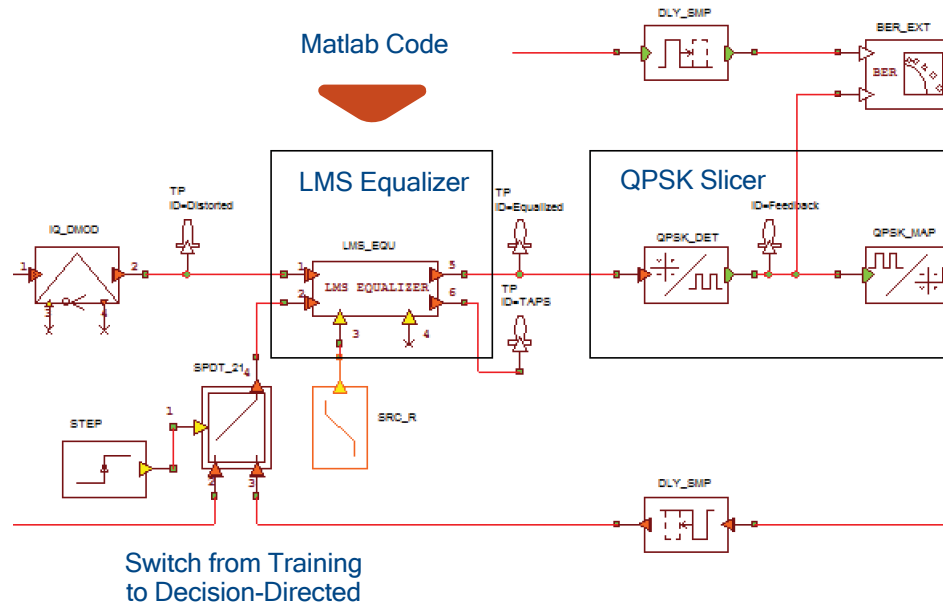

*VSS software boasts an efficient and complete design environment for making RF cascade calculations at interior points of the RF link to perform EVM measurements.*

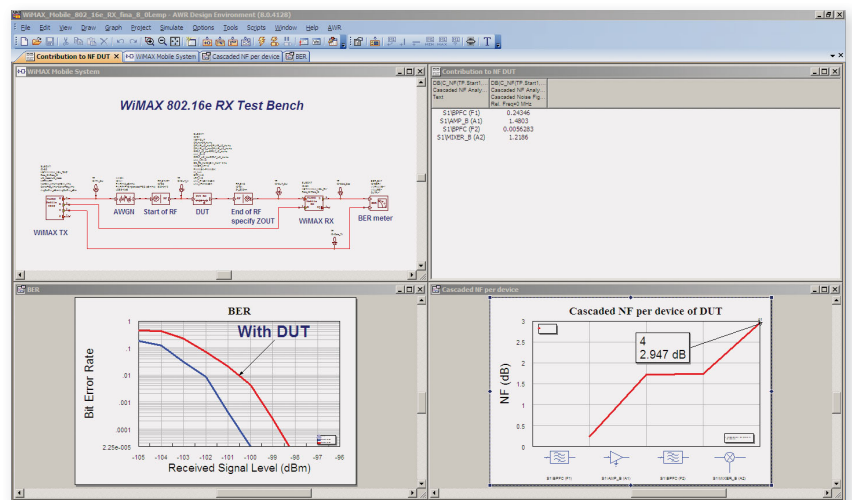

*Above is a receiver sensitivity analysis performed with VSS.*



www.awrcorp.com  
www.awr.tv

## USA

Corporate Headquarters  
AWR Corporation  
1960 E. Grand Avenue, Suite 430  
El Segundo, CA 90245  
+1 310 726 3000  
+1 310 726 3005 (fax)

## Japan

AWR Japan KK  
Level 5, 711 Building  
7-11-18 Nishi-Shinjuku, Shinjuku-ku  
Tokyo 160-0023 Japan  
+81 3 5937 4803

## UK

AWR UK  
2 Hunting Gate  
Hitchin, Herts  
SG4 0TJ, UK  
+44 (0) 1462 428 428

## Finland

AWR - APLAC  
Lars Sonckin kaari 16  
FI-02600 Espoo, Finland  
+358 10 834 5900

## France

AWR France  
140 Avenue Champs Elysees  
75008 Paris, France  
+33 1 70 36 19 63

## VSS in the Design Process

- ◀ Development of component specifications
- ◀ Algorithm development
- ◀ Creation of modulated signals
- ◀ Co-simulation with circuit tool
- ◀ End-to-end simulations
- ◀ Prediction of wireless conformance tests
- ◀ Hardware-in-loop simulations

## Features at a Glance

- ◀ Seamless integration with Microwave Office and Analog Office design suites, enabling APLAC<sup>®</sup> harmonic balance, EM, and/or linear co-simulation
- ◀ RFB for cascaded RF measurements



- ◀ RFI for identification of intermodulation product
- ◀ Optimization and yield analysis
- ◀ RF chain impairment analyses:
  - Behavioral blocks
  - Harmonic balance and linear co-simulation with system
  - Device measurement import such as phase noise, Touchstone data, and spur tables
- ◀ Key measurements such as EVM, ACPR, and integrated phase noise
- ◀ Impedance mismatch to monitor VSWR and its impact on the system
- ◀ Communications test benches for cellular, PCS, WiFi, WiMAX, and more
- ◀ R&S<sup>®</sup> WinIQSIM2<sup>™</sup> software (optional) for communications standards inclusive of 802.11n, WiMAX, WLAN, LTE, 1xEV-DO, CDMA200, EDGE/GSM, TD-SCDMA, DVB and more (contact us for latest standards)
- ◀ Signal generators for custom signals
- ◀ Fixed-point library simulation matches mathematics to hardware
- ◀ TestWave module (optional) integrates instruments within VSS to evaluate system performance using real signals